

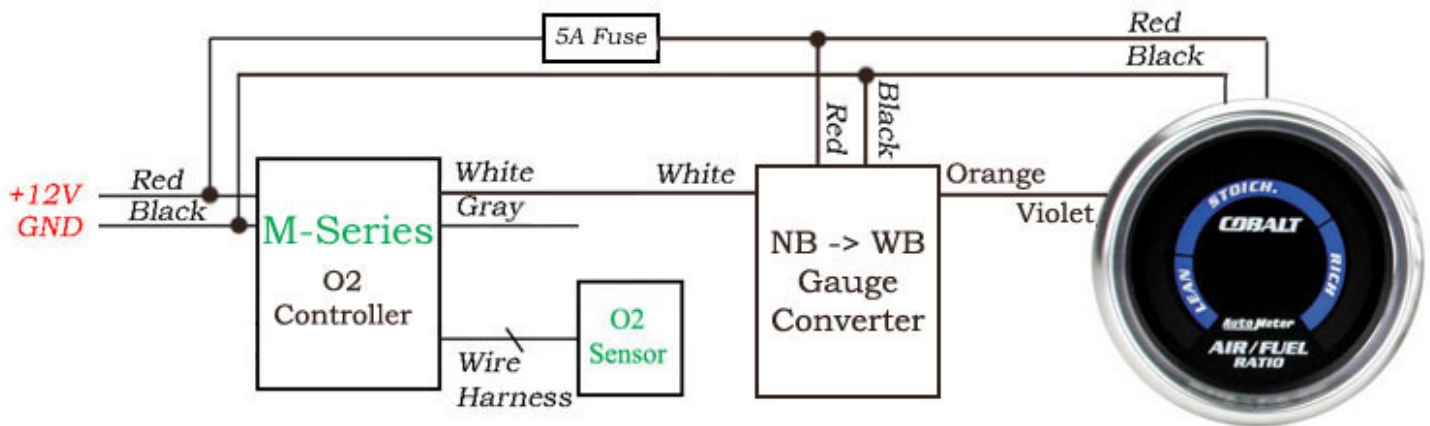

Narrowband to Wideband Gauge Converter

Version 1.2 February 9, 2006



1. Power to the NB->WB Gauge Converter is connected to a 12V source. This should be the same power connection as your gauge and M-Series wideband controller.
2. Connect the input of the NB->WB Gauge Converter (white) to the output of the M-Series controller (white).
3. Connect the input of the narrowband gauge (violet for AutoMeter Gauges) to the output of the NB->WB Gauge Converter (orange).
4. It is recommended that the Gauge Converter and the Gauge is fused (5Amps) for safety.

*For non AutoMeter gauges, the orange wire from the NB->WB Gauge Converter connects to the signal input wire to your gauge. Refer to your gauge's wiring diagram for proper identification of this signal.

LIMITED WARRANTY: PLX Devices Inc. warrants this product to be free from defects for 90 days from the date of purchase. If applicable, Oxygen sensors and other non-serviceable items are excluded from stated warranty. Serviceable goods must be determined by PLX Devices to be defective before any warranty or replacement is issued. PLX Devices' obligation under warranty shall be limited to repairing or replacing, under the discretion of PLX Devices, any part proven defective. This warranty is limited to the repair or replacement of parts in the manufactured good and the necessary labor done to affect its repair or replacement.

SERVICE UNDER WARRANTY: In the unlikely event that your PLX Devices hardware should fail during the warranty period, a Return Material Authorization number (RMA) must be first retrieved from PLX Devices Customer Support. Support can be contacted through email: support@plxdevices.com or by phone: 408-745-7591. All serviceable goods must be packaged securely with proof of purchase, RMA number, with all shipping charges prepaid and shipped to PLX Devices Inc. Goods returned under warranty must be received by PLX Devices Inc. within ten (10) business days after the RMA number has been issued. Goods received after this period is subject to fees for the service of repair or replacement. All repaired or replaced items shall be warranted for the remainder of the original product warranty.

RETURNS AND RESTOCKING FEE: A 15% restocking fee will apply to applicable PLX Devices products for refund. All returns are to be packed in original condition including packaging, documentation, manuals, and accessories. Returns that do not include all the accessories and components may be returned to the customer or charged on a per item basis. The customer assumes responsibility for product until receipt at PLX Devices Inc., shipping via an insurable carrier is recommended. Any unauthorized shipping charges will be billed to the customer or shipment will be refused.

DISCLAIMER: PLX Devices Inc. shall not be liable for direct, special, incidental, or consequential damages resulting from any legal theory including, but not limited to, lost profits, downtime, goodwill, damage, injury to persons, or replacement of equipment and property due to improper installation, integration and/or misuse of any PLX Devices Inc.'s product(s). This warranty applies to the original purchaser of product and is non-transferable. All implied warranties shall be limited in duration to the said 90 day warranty period.

Revision History

Version 1.0 (6/29/05)	Initial release
Version 1.1 (8/31/05)	Revised format to PDF
Version 1.2 (2/9/06)	Added detailed information for Warranty and returns

Version 1.2 February 9, 2006

www.plxdevices.com

(408)745-7591

