



## M-400/M-500 Plug and Play Installation Instructions

**\*If you are not familiar with the vehicle's electrical systems, onboard sensors, and vehicle dynamics, DO NOT attempt to perform ANY installation of PLX Devices Inc. product(s). Please read the instructions completely through at least once before proceeding with the installation to minimize errors.**

### 1) Select a location to mount the M-400/M-500 Plug and Play Controller

Choose a location where the device does not obstruct driver's view and/or ability to safely control the vehicle. Avoid locations exposed to direct sunlight and high temperatures. Never mount the device in the engine bay. Excessive heat will cause failure and damage to the unit.

### 2) Antenna positioning

Due to the nature of wireless transmissions, the position and orientation of the transmitter antenna is **EXTREMELY** important in guaranteeing that a reliable wireless connection is established. Keep the antenna at least 3 inches away from other metal objects and position it where "line of sight" operation between your Wireless RX Module is maximized. Best performance is achieved when there are no objects in obstruction to the radiated energy between the two antennas.

PLX Devices offers a few accessories to maximize data logging performance.

- Coax extension cables – Can be used to relocate your transmitter antenna for more positioning options.
- Wireless to wired conversion cable – Completely illuminates wireless transmission. Signals are sent directly through a coax cable to your RX Module. This offers guaranteed 0% packet loss and optimal data logging performance.

### 3) Install the wideband oxygen sensor

Mount the wideband oxygen sensor before the catalytic converter and at least 24 inches downstream from your engine block or turbo for optimal performance. The sensor element will fail if it is exposed to exhaust gas temperatures above 850 deg Celsius. If you plan to replace your stock narrowband oxygen sensor with the PLX wideband, please read PLXApp004 online for more information. The sensor will directly screw into an 18mm X 1.5mm pitch sensor bung.

### 4) Connect the wire harness to the oxygen sensor

You will hear a "click" when the connectors are properly mated.



M-400



M-500

### 5) Connect power to M-400/M-500 Plug and Play

Connect the negative wire (black) to your vehicle's ground. This is usually the negative terminal of your automobile's battery. Connect the positive wire (red) to your vehicle's ignition power. This power is only supplied when your key is turned passed a specific position and is off when your key is removed.

If you plan to integrate the M-400/M-500 Plug and Play with other aftermarket devices by utilizing the analog output signal wires. Make sure that the negative wire (black) is connected as close as possible to your device's ground. This guarantees that both devices "see" the same reference ground and a more accurate interpretation of the output voltages will be achieved. Please refer to the PLXApp notes online for more information.

**6) Connect the wire harness to the M-400/M-500 Plug and Play device by mating the two white connectors**

**7) Install noise filtering capacitors.**

Ignore this step if you do not intend on using the M-400/M-500 narrowband output and/or wideband output . If you plan to integrate the M-400/M-500 with stand alone engine management systems, piggy back systems, data loggers or any other devices that utilize the two analog outputs (white, gray wires), noise filtering capacitors must be installed near the application. The included capacitors filter out unwanted electrical noise produced from your vehicle's ignition and other onboard systems. This provides added signal integrity for more accurate, reliable and consistent measurements.

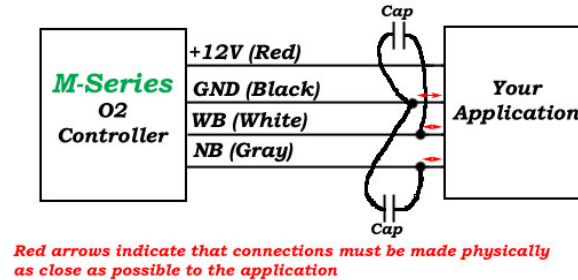

**8) Power up the M-400/M-500**

Do this before data logging inputs are connected to ensure that your controller is fully functional before proceeding. The unit takes approximately 45 seconds for the oxygen sensor to heat up and produce accurate measurements. If your M-400/M-500 Plug and Play display does not light up immediately, turn off the power immediately and check the power connection wires.

**9) Sensor calibration is not needed. The M-400/M-500 is self calibrating and no user intervention is required.**

When the wideband oxygen sensor is completely heated and exposed to free air, the analog linear wideband output (white wire) voltage should read 5.0V. The M-400/M-500 should display "Air."

**10) Power down the M-400/M-500**

**11) Determination of compatible signals for data logging**

The M-400/M-500 accepts two types of signal for data logging.

1. 2 Speed (Measures the frequency of signal pulses)
2. 4 Analog (Measures the voltage of a signal)

A compatible speed input is defined as an oscillating pulse which switches between a high voltage and a low voltage. A valid high voltage is 2V-25V with respect to ground (black wire) and a valid low voltage is 0-0.8V with respect to ground (black wire).

A compatible analog input is defined as a voltage between 0-5V with respect to ground (black wire). Any voltage between 5-25V will be capped to 5V and above 25V will cause damage to the logger.

M-400/M-500 data logger is NOT vehicle specific and was designed to be compatible with most signals to and from you ECU, but not all of them. It is up to the user to determine the viability and compatibility with the intended vehicle to be used based on the descriptions above.

**12) Connect input signals for data logger.**

After you have identified the signals you wish to data log. Connect the appropriate signals to the data log harness.

Signal	Color
Speed #1	Black
Speed #2	Brown
Analog #1	Red
Analog #2	White
Analog #3	Green
Analog #4	Blue

### 13) Install the USB RX Module device drivers.

Insert the USB RX Module into your USB port. Specify the location of your device driver when Windows prompts. Windows will recognize this device as "USB Serial Port (COM3-8)" in your Device Manager->Ports if everything is properly installed.

### 14) Install the PLXLogger software

Run setup.exe to start the PLXLogger installation. After installation is complete, start PLXLogger. Set the USB Port# to match the assigned com port number in step 11.

\*Always insert USB RX Module 10 seconds before starting PLXLogger. This gives time for Windows to properly detect the RX Module. Always close PLXLogger and wait 10 seconds before the USB RX Module is removed. This allows the software enough time to properly shutdown the RX Module resources.

### 15) Power up the device M-400/M-500

RX Signal indicator on the upper right should be blinking when your RX Module is within range with the M-400/M-500. The RX LED on your USB RX Module should also be rapidly blinking to indicate that a signal is present.

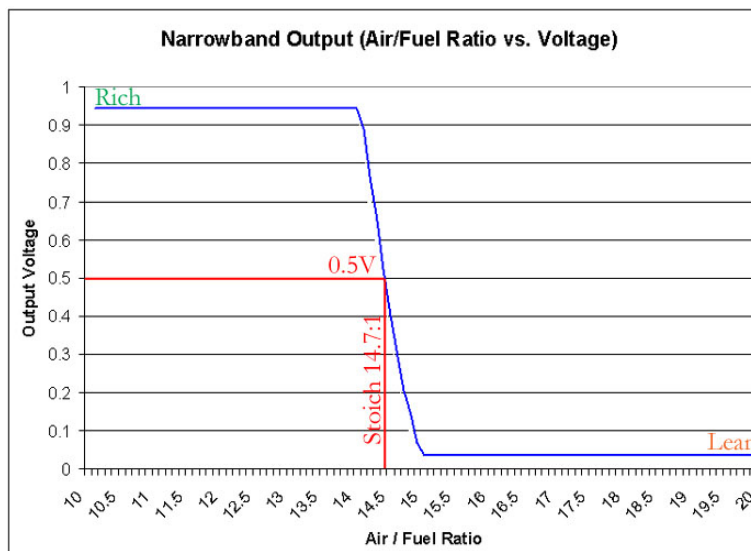
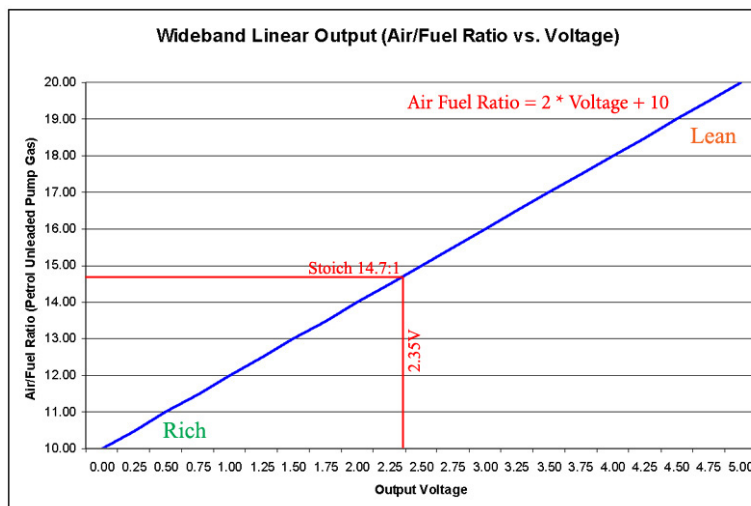

## Connection Diagram

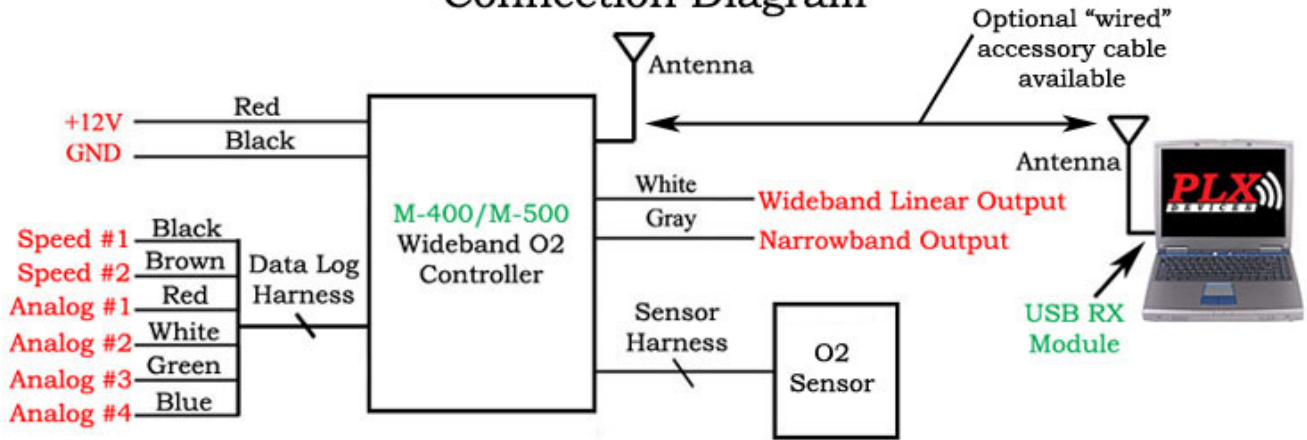

## Package Contents

1. M-400/M-500 wideband controller
2. Detachable transmitter antenna
3. USB RX Module
4. Wideband oxygen sensor (Optional for M-400)
5. Oxygen sensor harness
6. Data logger harness
7. Software CD
8. Two noise filtering capacitors 0.1uF

## Wireless Operation

M-400/M-500 is approved and certified to legally operate in “Wireless Mode” within The United States ONLY. Operation outside of The United States will require the use of the PLX M-Series Wire Conversion kit for “Wired Operation.”

## Terms of Use

PLX Devices Inc. does not guarantee the M-400/M-500’s functionality with any ECU, data logger or other devices that uses the input or output signals. Implementation and integration of the M-400/M-500 with any other device(s) must be done at your own risk. Improper installation and usage may lead to engine damage. Mount and install the M-400/M-500 in a location where it does not obstruct the driver’s view and/or ability or safely control the vehicle. Any modifications to the M-400/M-500 unit, unless expressly approved by PLX Devices Inc, could void the user’s authority to operate the device.

## LIMITED WARRANTY

PLX Devices Inc. warrants this product to be free from defects for 90 days from the date of purchase. If applicable, Oxygen sensors and other non-serviceable items are excluded from stated warranty. Serviceable goods must be determined by PLX Devices to be defective before any warranty or replacement is issued. PLX Devices’ obligation under warranty shall be limited to repairing or replacing, under the discretion of PLX Devices, any part proven defective. This warranty is limited to the repair or replacement of parts in the manufactured good and the necessary labor done to affect its repair or replacement.

## SERVICE UNDER WARRANTY

In the unlikely event that your PLX Devices hardware should fail during the warranty period, a Return Material Authorization number (RMA) must be first retrieved from PLX Devices Customer Support. Support can be contacted through email: [support@plxdevices.com](mailto:support@plxdevices.com) or by phone: 408-745-7591. All serviceable goods must be packaged securely with proof of purchase, RMA number, with all shipping charges prepaid and shipped to PLX Devices Inc. Goods returned under warranty must be received by PLX Devices Inc. within ten (10) business days after the RMA number has been issued. Goods received after this period is subject to fees for the service of repair or replacement. All repaired or replaced items shall be warranted for the remainder of the original product warranty.

## RETURNS AND RESTOCKING FEE

A 15% restocking fee will apply to applicable PLX Devices products for refund. All returns are to be packed in original condition including packaging, documentation, manuals, and accessories. Returns that do not include all the accessories and components may be returned to the customer or charged on a per item basis. The customer assumes responsibility for product until receipt at PLX Devices Inc., shipping via an insurable carrier is recommended. Any unauthorized shipping charges will be billed to the customer or shipment will be refused.

## DISCLAIMER

PLX Devices Inc. shall not be liable for direct, special, incidental, or consequential damages resulting from any legal theory including, but not limited to, lost profits, downtime, goodwill, damage, injury to persons, or replacement of equipment and property due to improper installation, integration and/or misuse of any PLX Devices Inc.’s product(s). This warranty applies to the original purchaser of product and is non-transferable. All implied warranties shall be limited in duration to the said 90 day warranty period.

## Declaration of Conformity

PLX Devices Inc. 24180 Dawnridge Dr. Los Altos, CA 94024 (650)793-3733 declare under our sole responsibility that the product, “Wireless M-Series,” complies with Part 15 of the FCC Rules. Operation is subject to the following two conditions: (1) this device may not cause harmful interference, and (2) this device must accept any interference received, including interference that may cause undesired operation.

## FCC Digital Device Compliance

This equipment has been tested and found to comply with the limits for a Class B digital device, pursuant to Part 15 of the FCC Rules. These limits are designed to provide reasonable protection against harmful interference in a residential installation. This equipment generates uses and can radiate radio frequency energy and, if not installed and used in accordance with the instructions, may cause harmful interference to radio communications. However, there is no guarantee that interference will not occur in a particular installation. If this equipment does cause harmful interference to radio or television reception, which can be determined by turning the equipment off and on, the user is encouraged to try to correct the interference by one or more of the following measures:

- Reorient the receiving antenna
- Increase the separation between the equipment and receiver
- Move the computer away from the receiver
- Connect the equipment into an outlet on a circuit different from that to which the receiver is connected

PLX Devices Inc.  
1261 Birchwood Dr. Sunnyvale, CA 94086  
[support@plxdevices.com](mailto:support@plxdevices.com)